

# Malanda Shower System

Product Code: **MASYS1200R**



Shower Screen / Walls



Shower Base

The Malanda shower system is a 3 part, low maintenance, leak resistant space consisting of a sliding shower screen with innovative round, stainless steel rollers and an acrylic 2-sided shower wall and shower base. This space saving design offers generous height and an interior/exterior stainless steel handle.



## SHOWER SCREEN

- AS/NZ Standard 1288:2006
- Easy install gasket wall system
- \*Adjustable wall channels (24mm)
- Sliding door is suitable for an alcove installation
- Interior/exterior stainless steel handle
- Right or left hand door entry
- Soft magnetic door closing system
- Anti-fungal and UV resistant seals
- Dripless door strips
- EZI clean glass coating
- Fully concealed fixtures
- Corrosion resistant steel fittings
- Space saving design

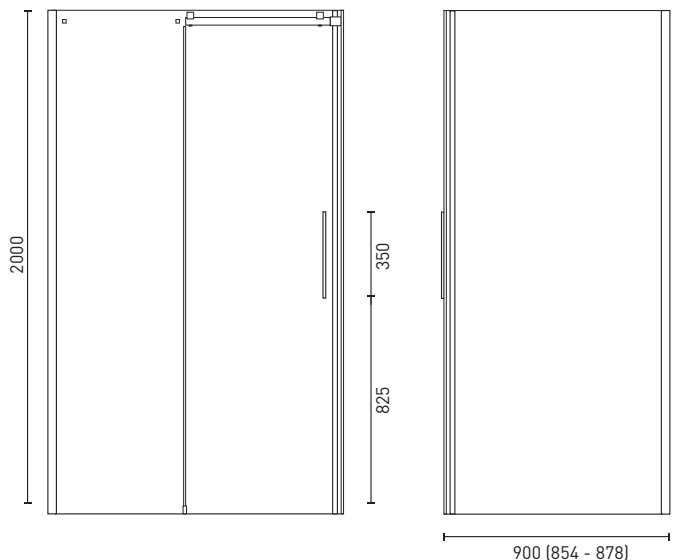

## PRODUCT SPECIFICATIONS

Material:	Aluminium / Chrome / Clear 8mm toughened safety glass
Length:	1200mm (1154 - 1178)*
Width:	900mm (854 - 878)*
Height:	2000mm
Net Weight:	74kgs
Warranty:	5 years* (refer to decina.com.au)

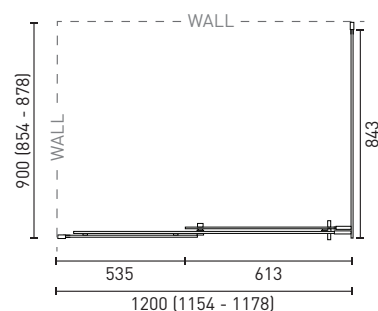

## SHOWER WALLS

- Made to AS/NZ Standard 3588:1996
- Easy to install
- Easy to clean and maintain
- Reduces mould
- Long-lasting durability

### PRODUCT SPECIFICATIONS

Material:	2mm coextruded ABS acrylic, high gloss white
Width:	1183mm
Depth:	883mm
Height:	2005mm
Net Weight:	10kg
Warranty:	5 years* (refer to decina.com.au)

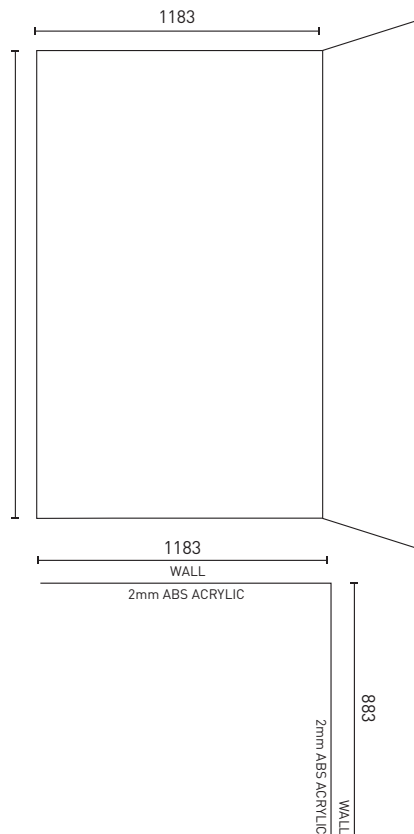

## SHOWER BASE

- Made to AS/NZ Standard 3588:1996
- Can be fully integrated into walls
- Tile bead on three sides
- Steel rod reinforced base
- Triple reinforced with fiberglass, timber and resin
- Rear outlet position
- Chrome friction lock removable waste cover
- 49mm low entry height
- Self-supporting feet
- No mortar bed required
- Slip resistant
- Easy to clean and maintain

### PRODUCT SPECIFICATIONS

Material:	Premium sanitary grade acrylic, high gloss white / chrome
Width:	1200mm
Depth:	900mm
Height:	64mm (base height to the top of the tile bead)
Net Weight:	28kg
Warranty:	10 years (refer to decina.com.au)

