

# Floriano Shower System

Product Code: **FLSYSCURVE**



Shower Screen / Walls



Shower Base

The Floriano shower system is a 3 part, low maintenance, leak resistant shower area consisting of a chrome, curved sliding shower screen with an exterior chrome handle, an acrylic 2-sided shower wall and curved shower base. This design offers generous height and maximizes space in the bathroom.



## SHOWER SCREEN

- AS/NZ Standard 1288:2006
- Easy install gasket wall system
- Adjustable wall channel (8mm\*)
- Right or left hand door entry
- Soft magnetic door closing system
- Anti-fungal & UV resistant seals
- Dripless door strips
- EZI clean glass coating
- Fully concealed fixtures
- Corrosion resistant steel fittings

## PRODUCT SPECIFICATIONS

**Material:** Aluminium / Chrome / Clear 6mm toughened safety glass

**Length:** 1000mm [957 - 965]\*

**Width:** 1000mm [957 - 965]\*

**Height:** 2000mm

**Net Weight:** 64kgs

**Warranty:** 5 years\* (refer to [decina.com.au](http://decina.com.au))

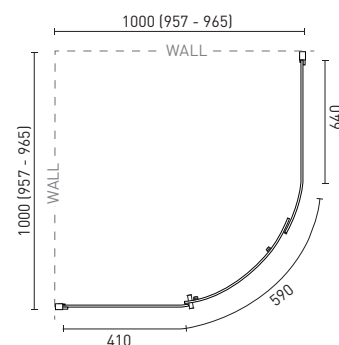
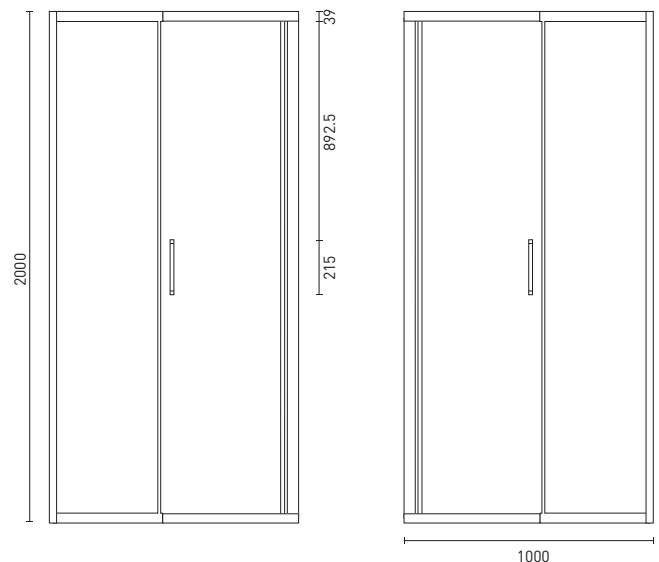

## SHOWER WALLS

- Made to AS/NZ Standard 3588:1996
- Easy to install
- Easy to clean and maintain
- Reduces mould
- Long-lasting durability

### PRODUCT SPECIFICATIONS

Material: 2mm coextruded ABS acrylic, high gloss white

Width: 1183mm

Depth: 883mm

Height: 2005mm

Net Weight: 10kg

Warranty: 5 years\* (refer to decina.com.au)

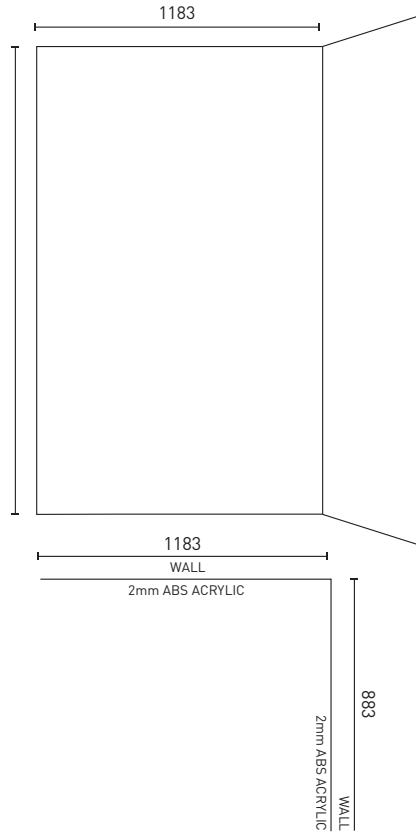

## SHOWER BASE

- Made to AS/NZ Standard 3588:1996
- Can be fully integrated into walls
- Tile bead on three sides
- Steel rod reinforced base
- Triple reinforced with fiberglass, timber and resin
- Rear outlet position
- Chrome friction lock removable waste cover
- 49mm low entry height
- Self-supporting feet
- No mortar bed required
- Slip resistant
- Easy to clean and maintain

### PRODUCT SPECIFICATIONS

Material: Premium sanitary grade acrylic, high gloss white / chrome

Width: 1000mm

Depth: 1000mm

Height: 64mm (base height to the top of the tile bead)

Net Weight: 24kg

Warranty: 10 years (refer to decina.com.au)

