

# Carina Counter Top Square Basin

Product Code [high gloss white]: **CABCTW**  
Product Code [matte black]: **CABCTB**



The Carina square counter top basin features an ultra thin edge & is designed to be mounted on top of a vanity or counter top bench, combined with a vessel or wall basin mixer.

- AS/NZ Standard AS1172.4.2019
- Counter top basin
- Ultra-thin edge

## PRODUCT SPECIFICATIONS

Colour:	High gloss white or Matte black
Material:	Premium vitreous china
Length:	405mm
Width:	405mm
Height:	110mm
Capacity:	9.5L
Basin Type:	Counter top
Net Weight:	9kg
Warranty:	10 years* (refer to decina.com.au)

## OPTIONAL ACCESSORIES

- 32mm pop-up basin waste - chrome **WA004**
- 32 X 40mm Quattro pop-up basin waste - chrome **WA005**
- 32mm pop-up basin waste - gloss white **WA006**
- 32mm pop-up basin waste - matte black **WA008**

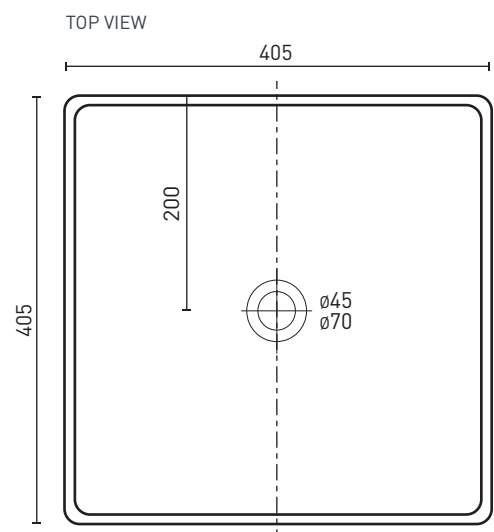
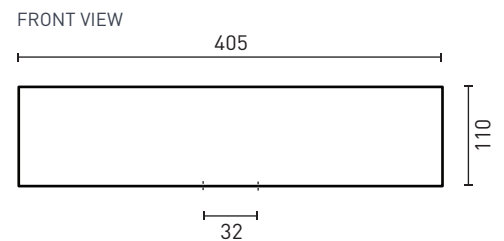

**DECINA**  
DISCOVER INDULGENCE

[DECINA.COM.AU](https://www.decina.com.au) 1300 DECINA

\*Warranty T&Cs apply, visit [decina.com.au](https://www.decina.com.au) Decina reserves the right to change specifications without notice. Due to manufacturing tolerances dimensions may vary +/- 5mm. We recommend installation does not start until after delivery. Please confirm all particulars prior to purchase, call 1300 DECINA or visit [decina.com.au](https://www.decina.com.au)