

DECINA

DISCOVER INDULGENCE

ORION FREESTANDING DOLCE VITA SPA BATH INSTALLATION & OWNER GUIDE

Thank you for purchasing a Decina Orion Freestanding Spa Bath.

This manual provides the correct steps and care advice for a safe and long lasting installation.

Manufactured from premium sanitary grade acrylic, Decina's freestanding spa baths are easy to install, with adjustable self-supporting feet & can be freely located anywhere in your bathroom.



ORFS1570FSDVSPA (16 jets) 1570(L) x 575 - 605(H) mm

THIS PRODUCT MUST BE INSTALLED BY A QUALIFIED TRADESMAN



PRE-INSTALLATION CHECKS

- ❗ Unpack & check the item is correct & no damage has occurred during transit.
- ❗ If there are any visible defects **DO NOT PROCEED WITH THE INSTALLATION & please contact the place of purchase immediately. ANY CLAIMS FOR DAMAGE WILL NOT BE ACCEPTED AFTER INSTALLATION.**
- ❗ Protect your spa bath before & during installation, scratches &/or cracks &/or surface damage sustained during or after the installation are not covered by warranty.
- ❗ Installation must be in accordance with building regulations & local authority requirements.
- ❗ Electrical installation must comply with AS:3000 - Electrical Wiring Rules.

MAINTENANCE

DECINA USES THE HIGHEST SANITARY GRADE ACRYLIC, HOWEVER NAKED FLAMES, CIGARETTES OR STRONG CHEMICALS SHOULD BE AVOIDED & REMOVED IMMEDIATELY TO PRESERVE THE HIGH GLOSS ACRYLIC SURFACE:

- ❗ When filling the bath start with cold water to allow the bath to gradually adapt to the temperature.
- ❗ After using your bath clean with a soft cloth & warm soapy water to clean any oils or soap, to prevent tide marks & preserve the polished surface.
- ❗ Clean using warm soapy water & only mild liquid detergents. Do not use powders, pastes, creams, chemicals, window cleaning sprays or abrasive cleaners.
- ❗ Cream cleaners may only be used to remove stubborn marks.
- ❗ Scratches can be removed with a fine polish like Brasso.

INSTALLATION STEPS

STEP 1. PREPARATION

Unpackage your freestanding bath. Remove the protective packing from the bath, taking great care not to damage the bath or skirts.

Inspect the bath and skirts carefully to ensure that no damage has occurred during transportation. Ensure your bath does not come in contact with any rough surfaces which may scratch your bath. Place your freestanding bath on cardboard or carpet during installation.

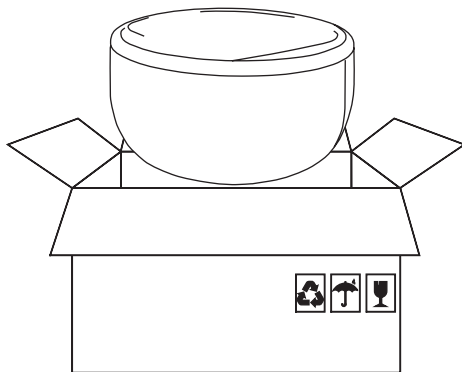

STEP 2. REMOVAL AND STORAGE OF THE SKIRTS

THE INSTALLER MUST BE AWARE THAT EACH SKIRT HAS A SPECIFIC LOCATION ON THE BATH.

One skirt is marked as **LEFT** or **LA** and the other skirt is marked as **RIGHT** or **RA**. Each side of the frame or the bath is marked similarly. If the markings are not clear, the installer is to clearly mark the skirt and frame to ensure that the skirts are in the correct positions.

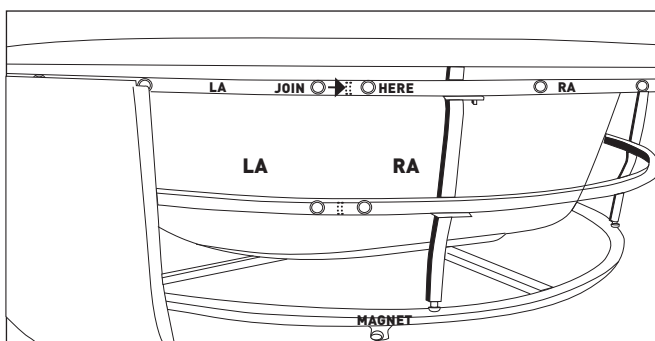

Remove each skirt from the bath and ensure that the skirts and frame are marked as shown.

- Begin at the skirt gap
- Pull edge towards you to separate.
- Gradually work your way anti-clockwise, peeling off the skirt.

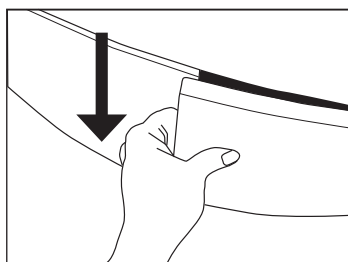

Place the inverted skirts on a flat surface as shown in a safe place.

NOTE THE SKIRTS MUST BE STORED AS SHOWN BELOW. LAYING THE SKIRTS IN ANY OTHER POSITION MAY CAUSE THE SKIRTS TO DISTORT.

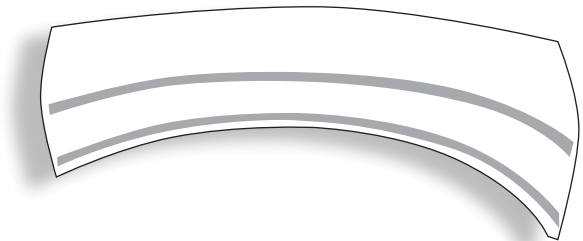

STEP 4. SPA BATH INSTALLATION

With the skirt removed, check the pump manifolds have not loosened in transport and then connect it to the drain outlet. We recommend using a Decina Flexible Connector.

Once the waste has been connected, and the spa is in position, with the skirts still removed, fill the bath with water and let sit for 10 minutes. Inspect under the bath for any visible leaking.

Start the spa pump and allow to run. After 10 minutes check for any visible leaking under the spa.

Allow the water to sit for a further 10 minutes and check for any visible leaking under the spa.

Drain the bath ensuring the water drains and there is no leaking through the flexible connector.

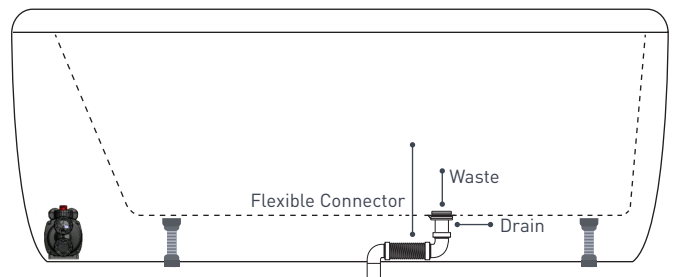

OWA004 Decina Flexible Connector + Pop-Up Waste

Min. clearance 100mm

OWA005 Decina Flexible Connector Min. clearance 80mm

STEP 5. CONNECTING YOUR SPA BATH

Electrically connect your spa bath based on your electrician's directions. Spa bath pumps must be fitted in accordance with relevant national wiring electrical standards AS3000. The pump is fitted with a standard 10A three pin plug power supply. The spa bath pump power connection must be accessible so that it can be switched OFF in case of an emergency, but must not be accessible by the bath user. Use one waterproof power point under the bath. Edgetec recommends that the pump be supplied by an isolating transformer or supplied through a residential current device (RCD) with a rated operating current of <30mA. If damage does occur to the power cord it must be replaced by Edgetec or an authorised service agent or suitable qualified person.

- The Spa Pump fits directly underneath the bath's perimeter
- The Spa Pump should be easily accessible for maintenance
- Waste positions can not be changed

STEP 6. REPLACING THE SKIRTS

1. Place the skirts on the floor around the bath.

ENSURE THAT THE ENDS OF THE SKIRTS LINE UP WITH THE JOIN LINE MARKS ON THE FRAME AND THAT THE SKIRTS ARE ON THE CORRECT SIDE OF THE BATH.

2. Lift the end of the skirt with the moulded step and locate it on the magnets as shown.

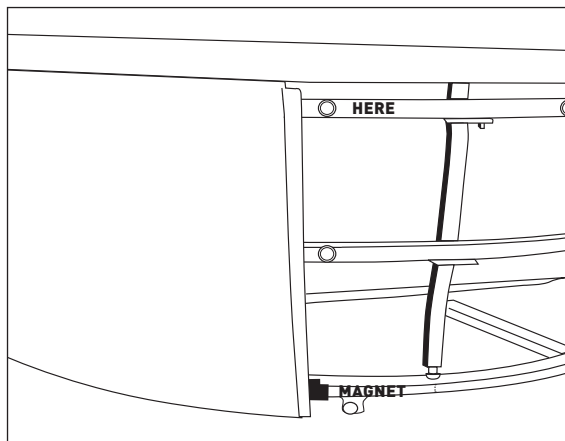

ENSURE THAT THE MOULDED STEP ON THE SKIRT IS LOCATED MIDWAY BETWEEN THE MAGNETS AT THE JOIN LINE.

3. Work around the skirt lifting it into a neat fit under the bath rim.

ENSURE THAT THE METAL PATCH LOCATED AT THE BOTTOM OF THE SKIRT END IS LOCATED CENTRALLY ON THE MAGNET ATTACHED TO THE BASE AS SHOWN BELOW.

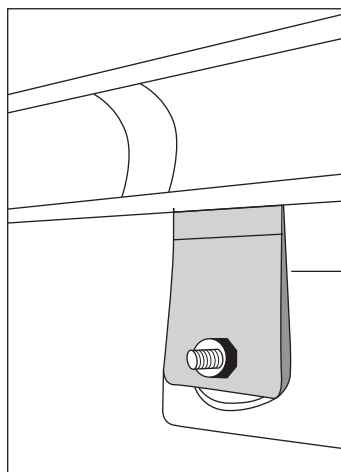

4. Lift the smooth end of the second skirt and position it over the moulded recess on the first skirt

5. Work around the second skirt lifting it into a neat fit under the bath rim.

6. Final adjustment of the skirts around the bath is done by gentle bumps with heel of the palm.

STEP 7.

Apply a thick bead of silicon around the bath base & the finished floor & allow it to set for 24 hours.

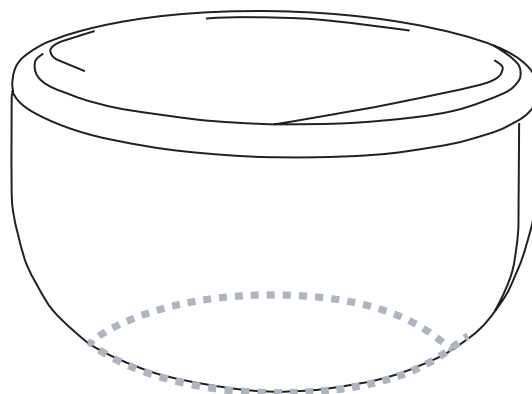

WARRANTY TERMS & CONDITIONS

All Decina products are manufactured to the highest standards and guaranteed to be free of defects, subject to the conditions outlined below. In addition to the statutory rights given under Australian Consumer Law, Decina offers the following extended warranty periods from the date of purchase or handover:

PRODUCT	WARRANTY	TERMS
ORION SPA BATH - Acrylic Shell	10 Years / 1 Year	Replacement Products / Parts & labour
SPA BATH PUMP	5 Years / 1 Year	Replacement Products / Parts & labour
SPA BATH JETS/FITTINGS	5 Years / 1 Year	Replacement Products / Parts & labour

The Decina warranty is only applicable when the product has been installed by a qualified tradesman, in full accordance with the installation instructions and statutory requirements. The warranty specifically EXCLUDES damages discovered AFTER installation.

Decina's responsibility for claims relating to impact damage ceases within 48 hours after delivery to the Decina re-seller's store.

The extended warranties only apply to faults or defects in the product arisen solely from faulty materials or workmanship in the products and does not apply to other defects for example from; damage, abuse, neglect or changes to the product supplied.

The warranty only extends to the supply of a replacement product or credit to the value of the purchase and excludes consequential damage ensuing from the product application or use. The responsibility for the removal and replacement of the product is with the installer and/or owner. Where the manufacturer "Decina" accepts that the product is at fault, the maximum contribution to the removal and replacement costs will be \$500.

Repairs of the Products other than by a Decina accredited or licensed service agent or technician are not covered.

In addition to this extended warranty, certain legislation (including the ACL) may give you certain rights which cannot be excluded, restricted or modified, this extended warranty must be read subject to such legislation and nothing in this warranty has the effect of excluding, restricting or modifying those rights.

To make a warranty claim, please visit the Decina website decina.com.au/warranty-claim/ or email services@decina.com.au and attach the following documentation:

- Proof of purchase (original invoice from the supplier)
- Details of the warranty claim including the date of installation, installer's details and head contractors
- Your contact details

If the Product has not been installed, please contact Decina to inspect the Product. If the claim is accepted, the Product can be returned or exchanged. Note: The extended warranty only applies to the original owner and is not transferable. Decina reserves the right to charge a service fee for any staff called to attend premises where products have been installed and the warranty claim is not authorised.

Copyright Feb 2019. Decina Bathroomware Pty Ltd. ABN 39845 084 033

PLEASE LEAVE THIS MANUAL WITH THE END USER