

# CARINA

## Santai Spa Bath

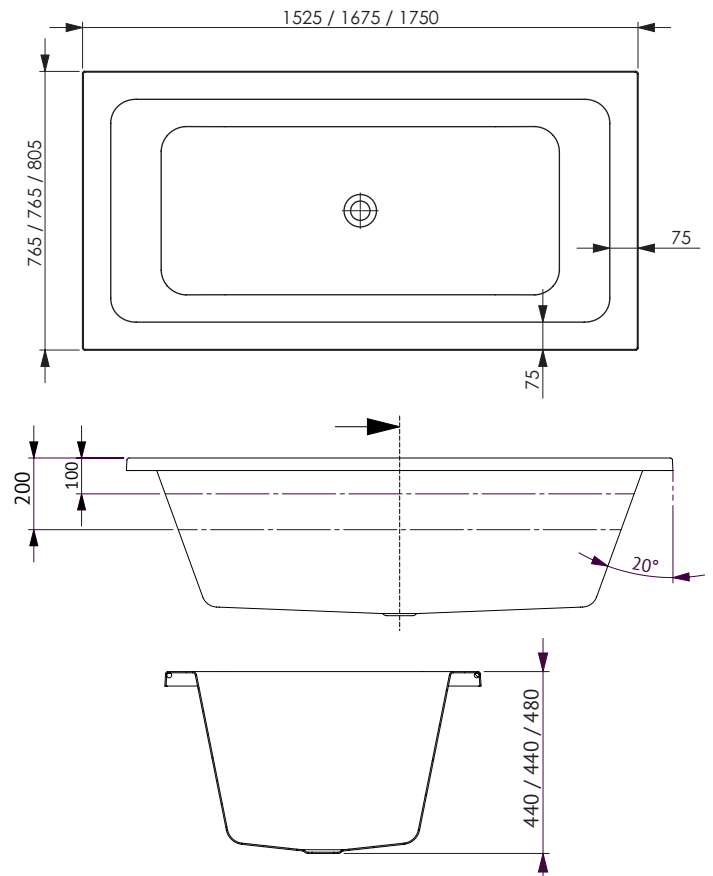

### CARINA SANTAI 12 JET SPA BATH

The Carina's planes have been angled to maximise bath space/utility, reclining comfort and function. Its form is that of an island bath so it has to be set away from adjoining walls allowing the viewer to truly appreciate its simple elegance.

#### SIZES (l)x(w)x(h)

- CA1525SAN12JW ~ 1525 x 765 x 440 (mm)
- CA1675SAN12JW ~ 1675 x 765 x 440 (mm)
- CA1750SAN12JW ~ 1750 x 805 x 485 (mm)

#### CAPACITY\* & NET WEIGHT

- 1525mm ~ 147 litres      34.0 kg
- 1675mm ~ 166 litres      37.0 kg
- 1750mm ~ 182 litres      45.0 kg

\*200mm below bath rim

#### WARRANTY:

- Ten year warranty -  
Conditions apply please see website for details

#### KEY FEATURES

- Inset bath with tile bead
- Made in Australia
- Made to AS/NZ Standard: 2023/1995
- Manufactured from premium sanitary grade acrylic
- High gloss white
- Water pressure adjustable Mod jets
- Centre waste position

#### SPA CONFIGURATION

- 600 watt auto heat boost pump
- Mod Power Button
- Mod Air Control (x2)
- Mod Mini Jet (x6)
- Mod Centro Jet (x6)
- Mod Suction

#### ACCESSORIES

- EZI Frame
- Fiore Headrest
- Overflow