

# CASCADE FIXED & SWING PIVOT PANEL *Bath Shower Screen*

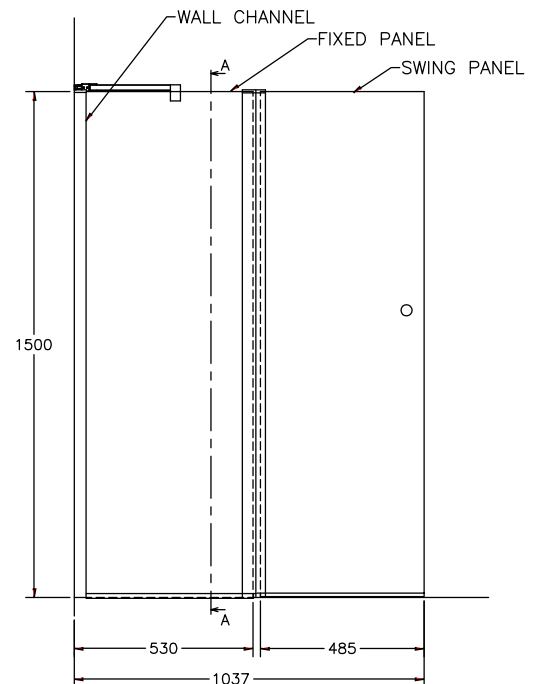

FRONT VIEW

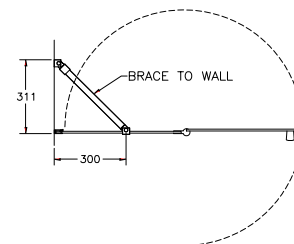

## CASCADE FIXED AND SWING PIVOT PANEL

The Cascade Fixed and Swing Pivot Panel provides a shower enclosure of over one metre long. Installed directly onto a tile bead the chrome plated pivot panel provides a seamless look while providing effortless access to the bath and taps.

The glass swing panel stays aligned with the bath edge and can be rotated up to 270 degrees in or out and fold all the way in for easy access, making it especially easy for bathing children.

### SIZE (l)x(h)

- *CAFSC* ~ 1037 x 1500 (mm) *(Overall size)*
- *Fixed Panel* ~ 530 x 1500 (mm)
- *Swing Panel* ~ 485 x 1500 (mm)

### NET WEIGHT

- 24.0 kg

## KEY FEATURES

- Invisible channel brackets (all fixings are on the inside of the channel) creates clean lines and seamless finish
- Made to Australian Standard: AS1288/2006
- Swing panel rotates 270 degrees in or out & folds all the way in
- Drip seal to bath
- 6mm toughened glass
- EZI Clean screen coating for easy cleaning
- Chrome plated handle prevents finger marks on the glass
- Chrome plated pivot panel
- Install directly onto a tile bead

## WARRANTY:

- Five year warranty -  
Conditions apply please see website for details